

Stony Brook University CSE 506: Operating Systems

Welcome to CSE 506

Introduction & Review

Don Porter

Stony Brook University CSE 506: Operating Systems

Why Grad OS?

- Primary Goal: Demystify how computers work

Stony Brook University CSE 506: Operating Systems

An example progression

- Undergrad OS:
 - High-level understanding of paging
 - Theoretical issues like fragmentation
- Grad OS (506): Build a pager
 - Solid understanding of how paging SW + HW work
- Advanced Grad OS (624): Read novel research papers
 - Do creative things with paging: virtualization, security, etc

Stony Brook University CSE 506: Operating Systems

506: Learn by doing

- You will write major chunks of your own OS
 - Memory management, context switching, scheduler, file system, IPC, network driver, shell, etc.
 - Linux scheduler:
 - Difficult to understand just by reading source
 - Small modifications require first understanding the code
 - Impossible to replace/reimplement
 - No substitute for building it yourself!

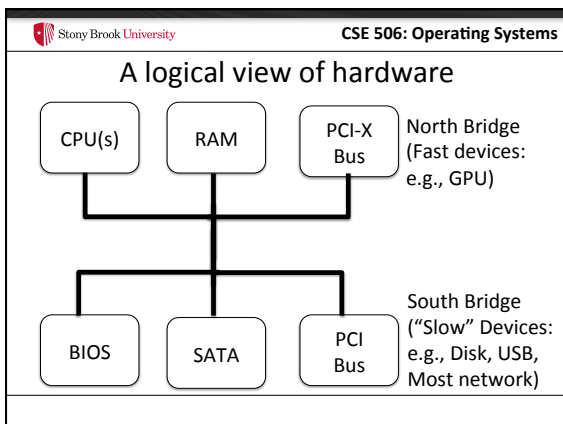

Stony Brook University CSE 506: Operating Systems

Fewer Bridges

- Newer system organizations are moving more devices to the North bridge, and consolidating more things on the CPU itself.

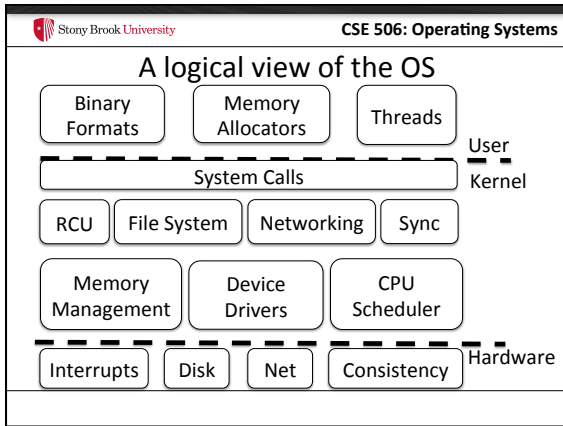

Stony Brook University CSE 506: Operating Systems

Labs, cont.

- This course is **coding intensive**
 - You should know C, or be prepared to remediate quickly
 - You will learn basic, inline x86 assembly
 - You must learn on your own/with lab partner
- The lab is difficult, but worthwhile
 - You will want to commemorate, with a T-shirt, tattoo, etc.

Stony Brook University CSE 506: Operating Systems

JOS

- Developed at MIT, used at several top schools
 - The “J” is for Josh Cates, not Java
- In C and Assembly, boots on real PC hardware
 - You get the skeleton code, fill in interesting pieces
- Build the right intuitions about real OSes
 - but with much simpler code

Stony Brook University CSE 506: Operating Systems

JOS 64

- You will actually implement a 64-bit variant of JOS
- Developed at Stony Brook!
 - Primarily by Amit Arya and Abhinand Palicherla
 - Contributions also by: Vivek Kulkarni, Varun Agarwal, Chia-Che Tsai, Tao Zhang...
 - Some of these final projects or just contributions from a previous 506 course
 - See your name here next year if you add a particularly useful feature!

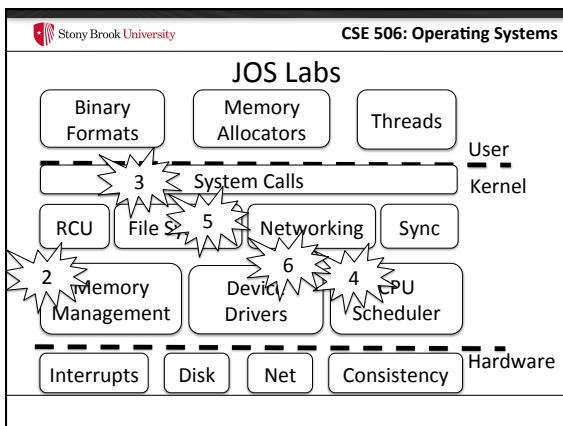

Stony Brook University CSE 506: Operating Systems

Last Lab

- Includes open ended project
 - Can add significant feature to JOS
 - Or do a research task on another system
- Plan ahead – proposals due 10/23
 - Note all deadlines on course website

Stony Brook University CSE 506: Operating Systems

Challenge Problems

- Each lab includes challenge problems, which you may complete for bonus points (generally 5—10 points out of 100)
 - Unwise to turn in a lab late to do challenge problems
 - Can complete challenge problems at any point in the semester—even on old labs
- Indicate any challenge problems completed in challenge.txt file

Stony Brook University CSE 506: Operating Systems

CSE 522

- This course can also count as your MS project course (CSE 522)
- Requirements: Same as 506, except:
 - You must do the labs alone
 - You must complete 1 challenge problem in each lab
- To enroll: you must first be in 506
 - Ask me and I will have you moved to 522

Stony Brook University CSE 506: Operating Systems

No Textbook

- You're welcome
- Several recommended texts
 - Several free on SBU safari online site
 - Others on reserve at library
 - Required readings will mainly be papers you can print out

Stony Brook University CSE 506: Operating Systems

Lectures

- Compare and contrast JOS with real-world OSes
 - Mostly Linux, some Windows or OS X, FreeBSD, etc.
- Supplement background on hardware programming
 - Common educational gap between OS and architecture

Stony Brook University CSE 506: Operating Systems

My Lecture Style

- I like participation and questions
- I can explain any concept in many ways, and explain missing background on the fly
 - ...but I can't read your mind—I need to know if you don't understand something!

Stony Brook University CSE 506: Operating Systems

SBU Capture

- Experiment: TLT will be recording the projection and audio (no video of me, sadly)
 - Recordings will be automatically posted to BlackBoard
 - Intended to help you study
 - Especially helpful for people without strong English
- **This is best effort**
 - No guarantee all lectures will be recorded
- **This is no substitute for lecture attendance**
 - Can't ask questions
- **If attendance suffers, I will stop recording lectures**

Stony Brook University CSE 506: Operating Systems

Prerequisites

- Undergrad OS
 - In some cases, industry experience is ok
 - Worth brushing up if it has been a while
 - In-class quiz, due before you leave
 - If you can't answer 50% of these questions, consider ugrad OS
- C programming
- Basic Unix command-line proficiency
- See me if you have already done the JOS lab, or similar

Stony Brook University CSE 506: Operating Systems

PhD vs. MS Sections

- This course was supposed to be split into 2 sections
 - I teach MS section
 - Prof. Honarmand teaches PhD section
- Benefits: More seats, more tailored material
 - But 85+% similar
- The two sections are *temporarily* merged
 - All students will take lectures from me until further notice
 - We expect to re-divide the sections later

Stony Brook University CSE 506: Operating Systems

Section 2: PhD

- Two parts:
 - Part 1: same material as MS section (up to Security)
 - Part 2: Introduction to some advanced OS topics
 - Emphasizing paper reading (it's a PhD section after all)
- 5 Lab assignments (same as first 5 in MS section)
 - 37% of grade
- Midterm and Final exams (same days as MS section)
 - 40% of grade (midterm: 20%, final: 20%)
- Paper reading and analysis
 - 18% of grade
- Presentation or Project
 - 15% of grade
- Yes, they sum up to 110%

Stony Brook University CSE 506: Operating Systems

Section 2: PhD (cont'd)

- There will be papers for reading and discussion
 - Occasionally in Part 1, mostly in Part 2
 - Should discuss papers on newsgroup (mandatory participation)
- In Part 2, we'll discuss advanced topics
 - Such as alternative OS architectures and security
- For the last 15%: Students can
 - present a set of assigned papers in Part 2
 - or -
 - do a research project
- Same groups as your lab assignments

Stony Brook University CSE 506: Operating Systems

Space in the class

- Wait list is currently full for MS section
- Grad students often over-enroll
 - Space likely to open up in first week
 - If you want in, keep showing up for a few lectures
- Worst case: Prof. Ferdman teaching 506 in spring
 - Likely to be offered every semester going forward

Stony Brook University CSE 506: Operating Systems

Course email list

- We will use Piazza this year, we will enroll classes
 - Both MS and PhD will share a discussion forum
- This is the primary announcement medium
- And for discussions about course work
 - Do not post code here or other solutions
 - Goal: Everyone can learn from general questions
- Material discussed on the mailing list can be an exam question

Stony Brook University CSE 506: Operating Systems

Other administrative notes

- Read syllabus completely
- 2 exams cover: lectures, labs, mailing list
- Every student will get a VM for lab work
 - You may use your own computer, staff can't support it
- All staff email goes to cs506ta@cs.stonybrook.edu
 - Except private issues for instructor only

Stony Brook University CSE 506: Operating Systems

VM Assignments

- Your VM is cse506-USER, where USER is your netid
- Each VM is hosted on the server esx1sc---esx4sc
 - You should receive an email with your server and initial password
- The account is cse506
- Once it is powered on, it will listen for ssh on port 130
- Change the password immediately
- Also, checkpoint your VM before you change things

Stony Brook University CSE 506: Operating Systems

Lab Partners

- Can work alone, but better with help
 - Some excellent students earned A's working alone
 - Many good students earned B's working alone
 - No need to be a hero
- Choose your own partners
 - Lab mailing list good for finding them
- Same for entire course
 - Changes only with instructor permission

Stony Brook University CSE 506: Operating Systems

To Do

- Email me your partner selection
- We will then create the git repository you will use to turn in your assignments
- In the meantime, clone the read-only, http repository to get started
- Please do this well in advance of the deadline

Stony Brook University CSE 506: Operating Systems

Academic Integrity

- I take cheating very seriously. It can end your career.
- In a gray area, it is your job to stay on right side of line
- Never show your code to anyone except your partner and course staff
- Never look at anyone else's code (incl. other universities)
- Do not discuss code; do not debug each other's code
- Acknowledge students that give you good ideas

Stony Brook University CSE 506: Operating Systems

Lateness

- Each group gets 72 late hours
 - List how many you use in slack.txt
 - Each day after these are gone costs a full letter grade on the assignment
- It is your responsibility to use these to manage:
 - Holidays, weddings, research deadlines, conference travel, Buffy marathons, release of the next Zelda game, etc.
- 3 Exceptions: illness (need doctor's note), death in immediate family, accommodation for disability

 Stony Brook University **CSE 506: Operating Systems**

Lab 1 assigned (soon)

- Due Monday, 9/8 at 11:59 pm, eastern.
- Instructions on website
- Quick demo

 Stony Brook University **CSE 506: Operating Systems**

Getting help

- TA's (TBD) will keep office hours
- Instructor keeps office hours
 - Note that “by appointment” means more time available on demand

 Stony Brook University **CSE 506: Operating Systems**

Questions?