

# Interrupts and System Calls

Don Porter

CSE 506

# Housekeeping

- Welcome Tas Amogh Akshintala and Yizheng Jiao (1/2 time) – Office Hours posted
- Next Thursday's class has a reading assignment
- Lab 1 due Monday 9/8
- All students should have VMs and private repos soon
  - Email Don if you don't have one by tonight
  - Unless you just got in the class since Wed night (sigh)

# Logical Diagram

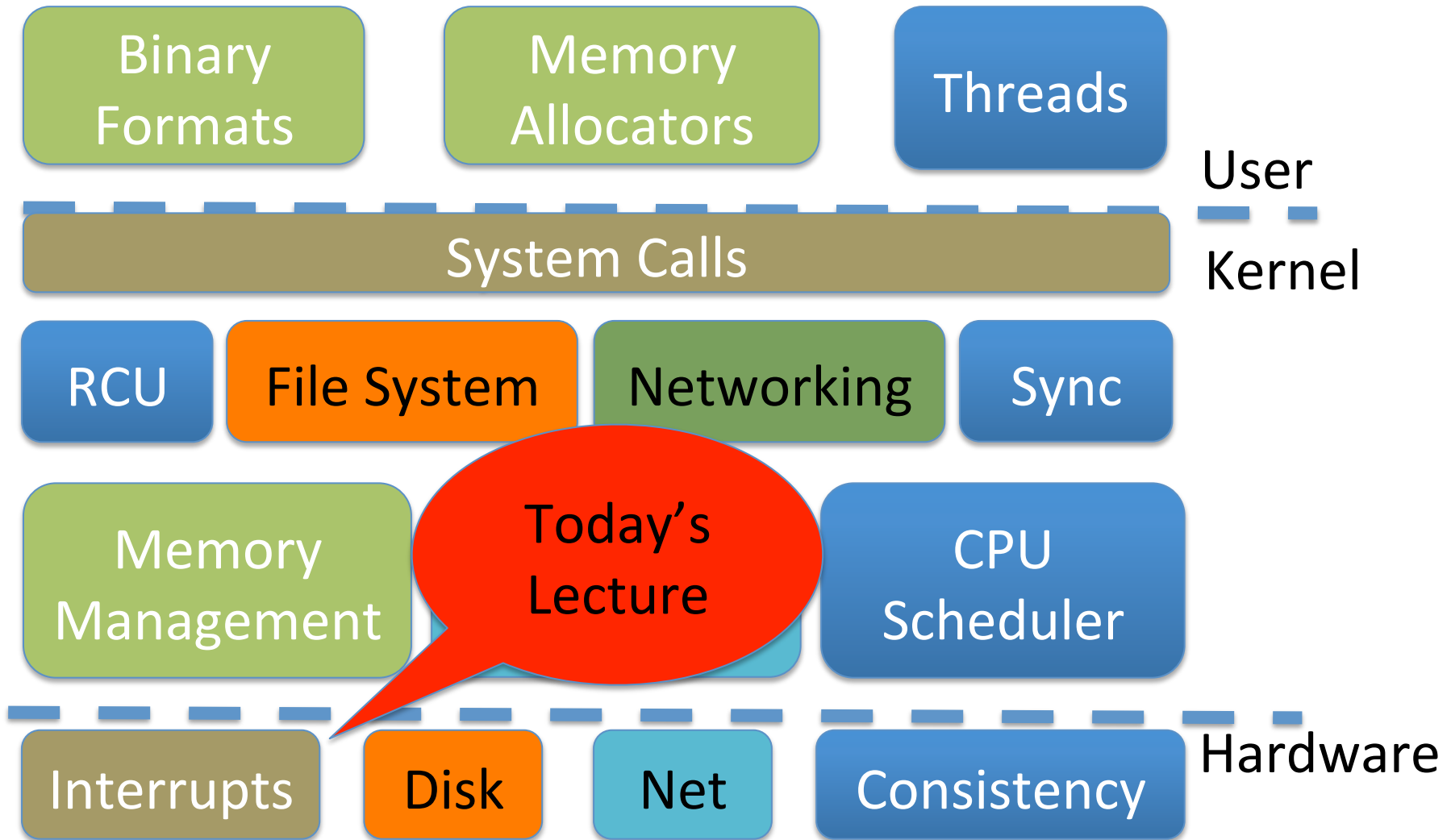

# Background: Control Flow

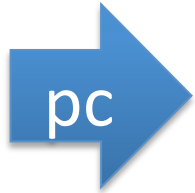

```
// x = 2, y =  
true  
  
if (y) {  
    2 /= x;  
    printf(x) ;  
} //...
```

```
void printf(va_args)  
{  
    //...  
}
```

**Regular** control flow: branches and calls  
(logically follows source code)

# Background: Control Flow

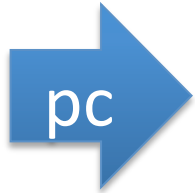

```

// x = 0
true
if (y) {
    2 /= x;
    printf(x);
} // ...
  
```

Divide by zero!  
Program can't make progress!

```

void handle_divzero()
{
    x = 2;
}
  
```

**Irregular** control flow: exceptions, system calls, etc.

## Lecture goal

- Understand the hardware tools available for **irregular control flow**.
  - I.e., things other than a branch in a running program
- Building blocks for context switching, device management, etc.

# Two types of interrupts

- Synchronous: will happen every time an instruction executes (with a given program state)
  - Divide by zero
  - System call
  - Bad pointer dereference
- Asynchronous: caused by an external event
  - Usually device I/O
  - Timer ticks (well, clocks can be considered a device)

# Intel nomenclature

- Interrupt – only refers to asynchronous interrupts
- Exception – synchronous control transfer
  
- Note: from the programmer's perspective, these are handled with the same abstractions



# Lecture outline

- Overview
- How interrupts work in hardware
- How interrupt handlers work in software
- How system calls work
- New system call hardware on x86

# Interrupt overview

- Each interrupt or exception includes a number indicating its type
- E.g., 14 is a page fault, 3 is a debug breakpoint
- This number is the index into an interrupt table

# x86 interrupt table

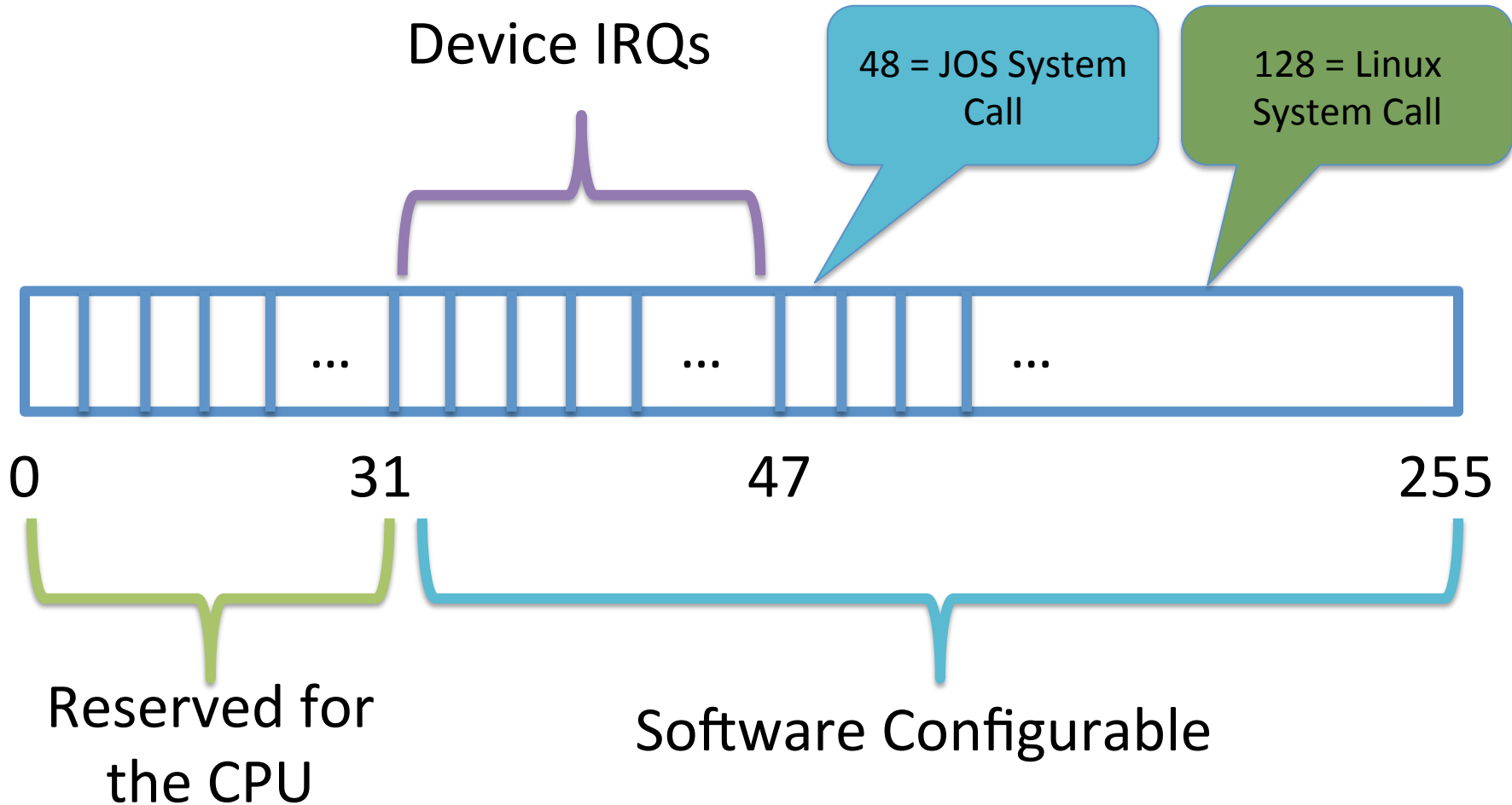

# x86 interrupt overview

- Each type of interrupt is assigned an index from 0—255.
- 0—31 are for processor interrupts; generally fixed by Intel
  - E.g., 14 is always for page faults
- 32—255 are software configured
  - 32—47 are for device interrupts (IRQs) in JOS
    - Most device's IRQ line can be configured
    - Look up APICs for more info (Ch 4 of Bovet and Cesati)
  - 0x80 issues system call in Linux (more on this later)

# Software interrupts

- The `int <num>` instruction allows software to raise an interrupt
  - 0x80 is just a Linux convention. JOS uses 0x30.
- There are a lot of spare indices
  - You could have multiple system call tables for different purposes or types of processes!
    - Windows does: one for the kernel and one for win32k

## Software interrupts, cont

- OS sets ring level required to raise an interrupt
  - Generally, user programs can't issue an `int 14` (page fault) manually
  - An unauthorized `int` instruction causes a general protection fault
    - Interrupt 13

## What happens (generally):

- Control jumps to the kernel
  - At a prescribed address (the interrupt handler)
- The register state of the program is dumped on the kernel's stack
  - Sometimes, extra info is loaded into CPU registers
  - E.g., page faults store the address that caused the fault in the `cr2` register
- Kernel code runs and handles the interrupt
- When handler completes, resume program (see `iret` instr.)

## How it works (HW)

- How does HW know what to execute?
- Where does the HW dump the registers; what does it use as the interrupt handler's stack?



## How is this configured?

- Kernel creates an array of Interrupt descriptors in memory, called Interrupt Descriptor Table, or IDT
  - Can be anywhere in memory
  - Pointed to by special register (`idt_r`)
    - c.f., segment registers and `gdtr` and `ldtr`
- Entry 0 configures interrupt 0, and so on

# x86 interrupt table

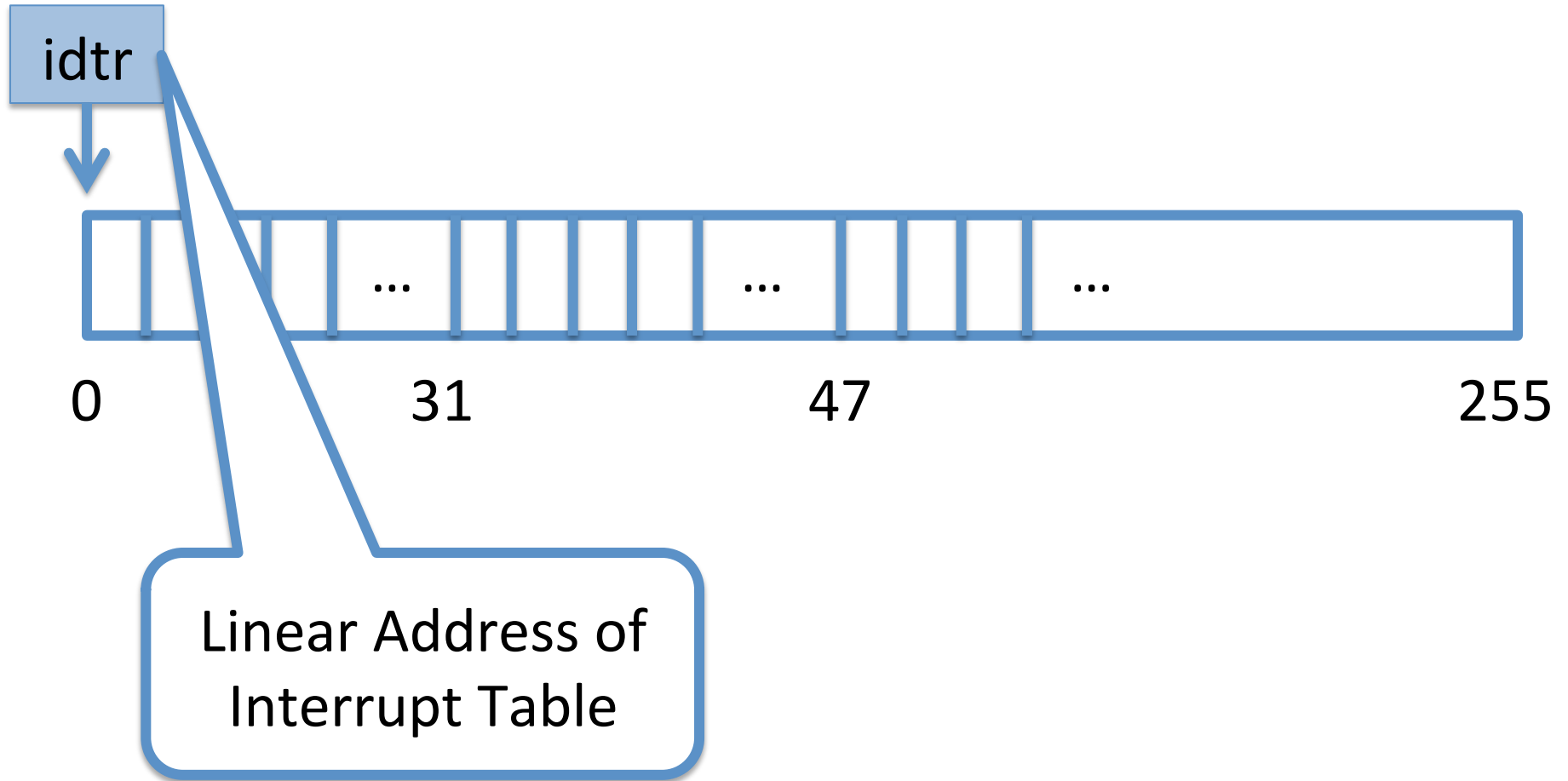

# x86 interrupt table

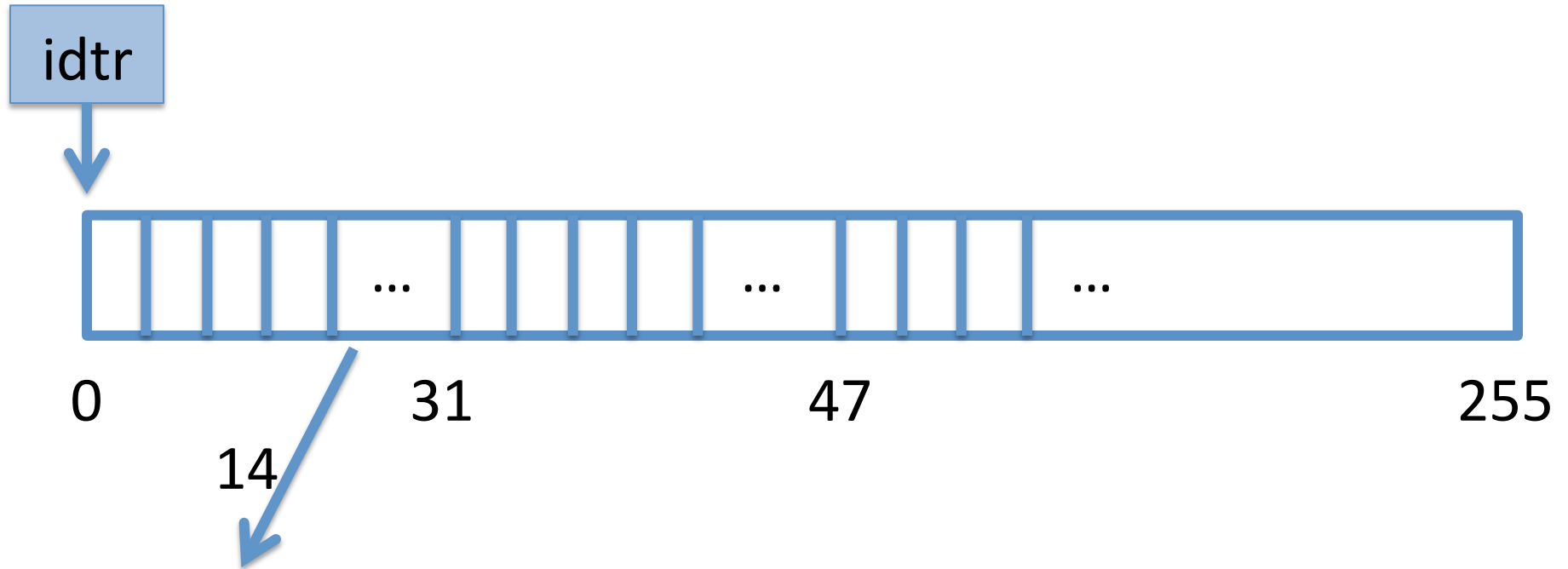

```
Code Segment: Kernel Code
Segment Offset: &page_fault_handler //linear addr
Ring: 0 // kernel
Present: 1
Gate Type: Exception
```

# Interrupt Descriptor

- Code segment selector
  - Almost always the same (kernel code segment)
  - Recall, this was designed before paging on x86!
- Segment offset of the code to run
  - Kernel segment is “flat”, so this is just the linear address
- Privilege Level (ring)
  - Ring that can raise this interrupt with an `int` instruction
- Present bit – disable unused interrupts
- Gate type (interrupt or trap/exception) – more in a bit

# x86 interrupt table

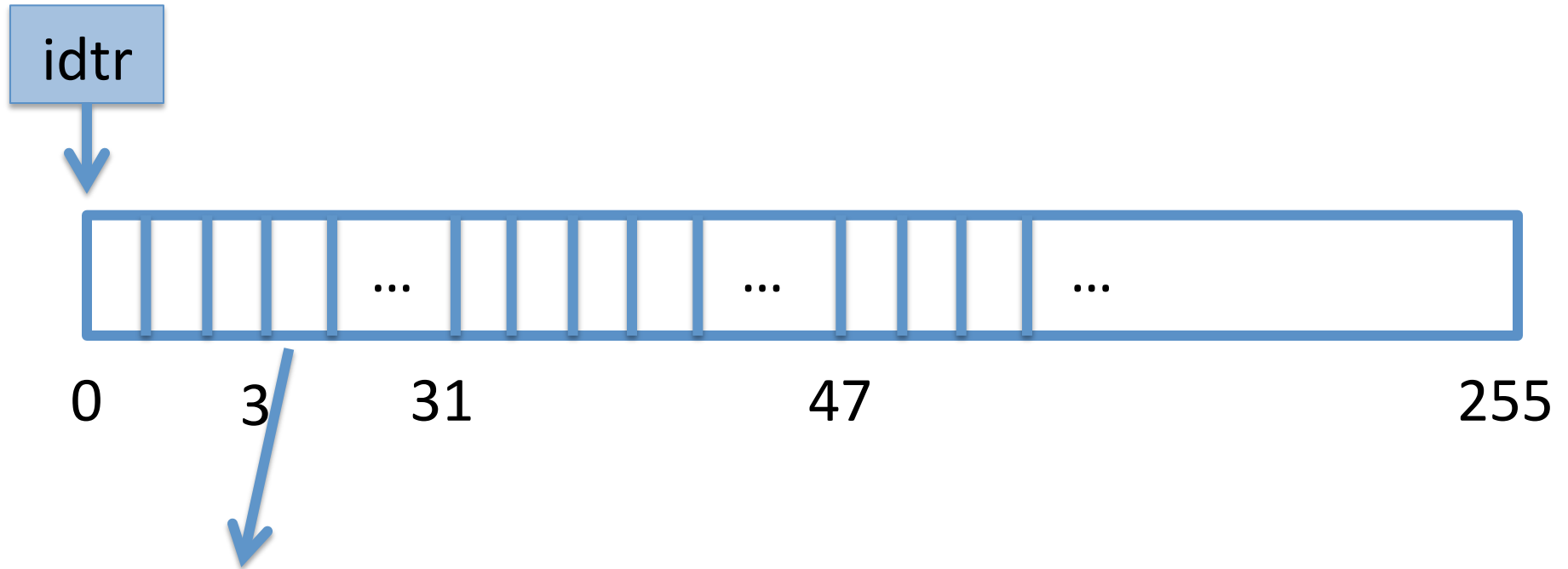

```
Code Segment: Kernel Code  
Segment Offset: &breakpoint_handler //linear addr  
Ring: 3 // user  
Present: 1  
Gate Type: Exception
```

## Interrupt Descriptors, ctd.

- In-memory layout is a bit confusing
  - Like a lot of the x86 architecture, many interfaces were later deprecated
- Worth comparing Ch 9.5 of the i386 manual with `inc/mmu.h` in the JOS source code

## How it works (HW)

- How does HW know what to execute?
  - Interrupt descriptor table specifies what code to run
    - And at what privilege (via code segment)
  - This can be set up once during boot for the whole system
- Where does the HW dump the registers; what does it use as the interrupt handler's stack?
  - Specified in the Task State Segment

# Task State Segment (TSS)

- Another segment, just like the code and data segment
  - A descriptor created in the GDT (cannot be in LDT)
  - Selected by special task register (tr)
  - Unlike others, has a hardware-specified layout
- Lots of fields for rarely-used features
- Two features we care about in a modern OS:
  - 1) Location of kernel stack (fields `ss0/esp0`)
  - 2) I/O Port privileges (more in a later lecture)



## TSS, cont.

- Simple model: specify a TSS for each process
  - Note: Only  $2^{13}$  entries in the GDT
- Optimization (JOS):
  - Our kernel is pretty simple (uniprocessor only)
  - Why not just share one TSS and kernel stack per-process?
- Linux generalization:
  - One TSS per CPU
  - Modify TSS fields as part of context switching

# Summary

- Most interrupt handling hardware state set during boot
- Each interrupt has an IDT entry specifying:
  - What code to execute, privilege level to raise the interrupt
- Stack to use specified in the TSS

# Comment

- Again, segmentation rears its head
- You can't program OS-level code on x86 without getting your hands dirty with it
- Helps to know which features are important when reading the manuals

# Lecture outline

- Overview
- How interrupts work in hardware
- **How interrupt handlers work in software**
- How system calls work
- New system call hardware on x86

# High-level goal

- Respond to some event, return control to the appropriate process
- What to do on:
  - Network packet arrives
  - Disk read completion
  - Divide by zero
  - System call

# Interrupt Handlers

- Just plain old kernel code

# Example

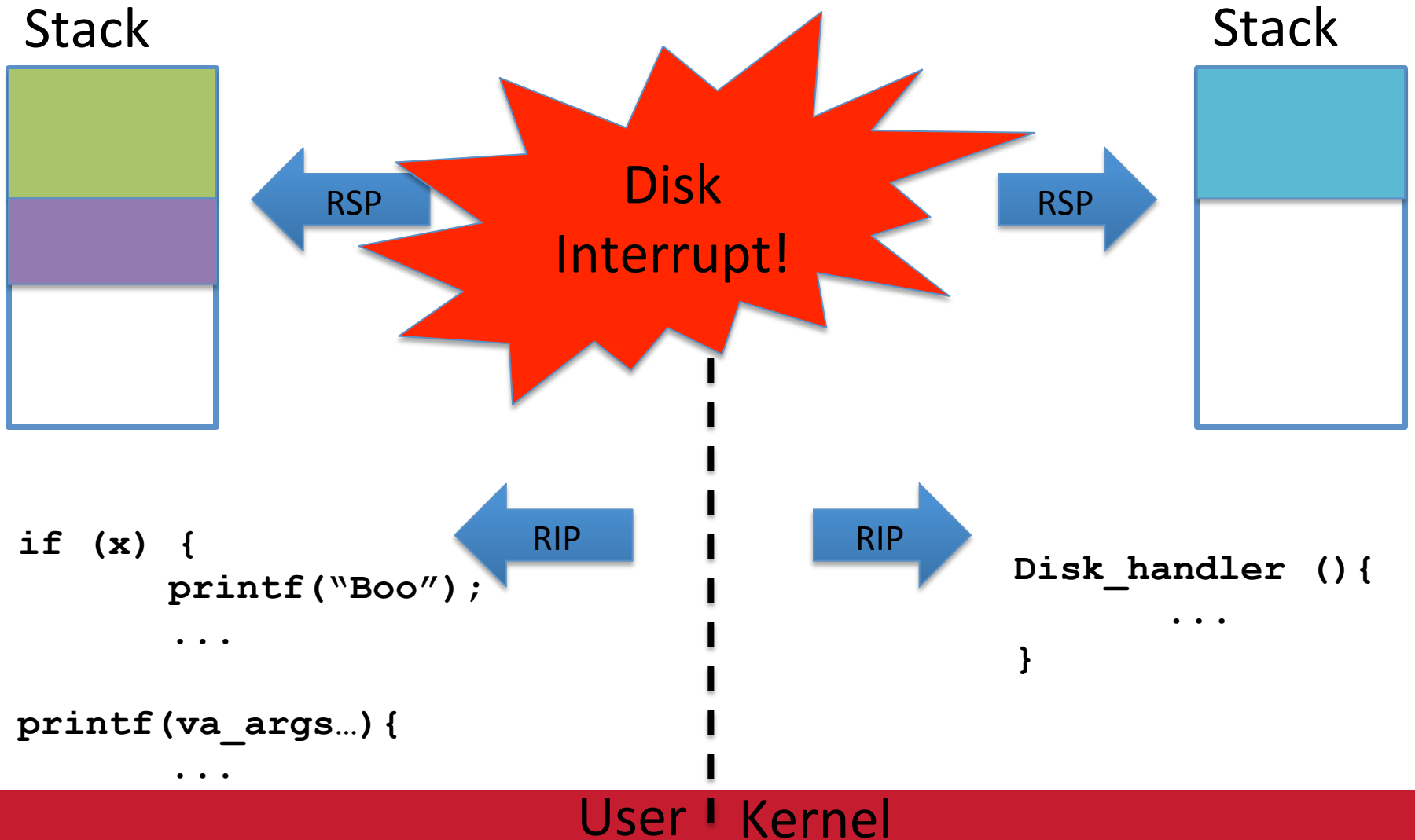

## Complication:

- What happens if I'm in an interrupt handler, and another interrupt comes in?
  - Note: kernel stack only changes on privilege level change
  - Nested interrupts just push the next frame on the stack
- What could go wrong?
  - Violate code invariants
  - Deadlock
  - Exhaust the stack (if too many fire at once)



# Example

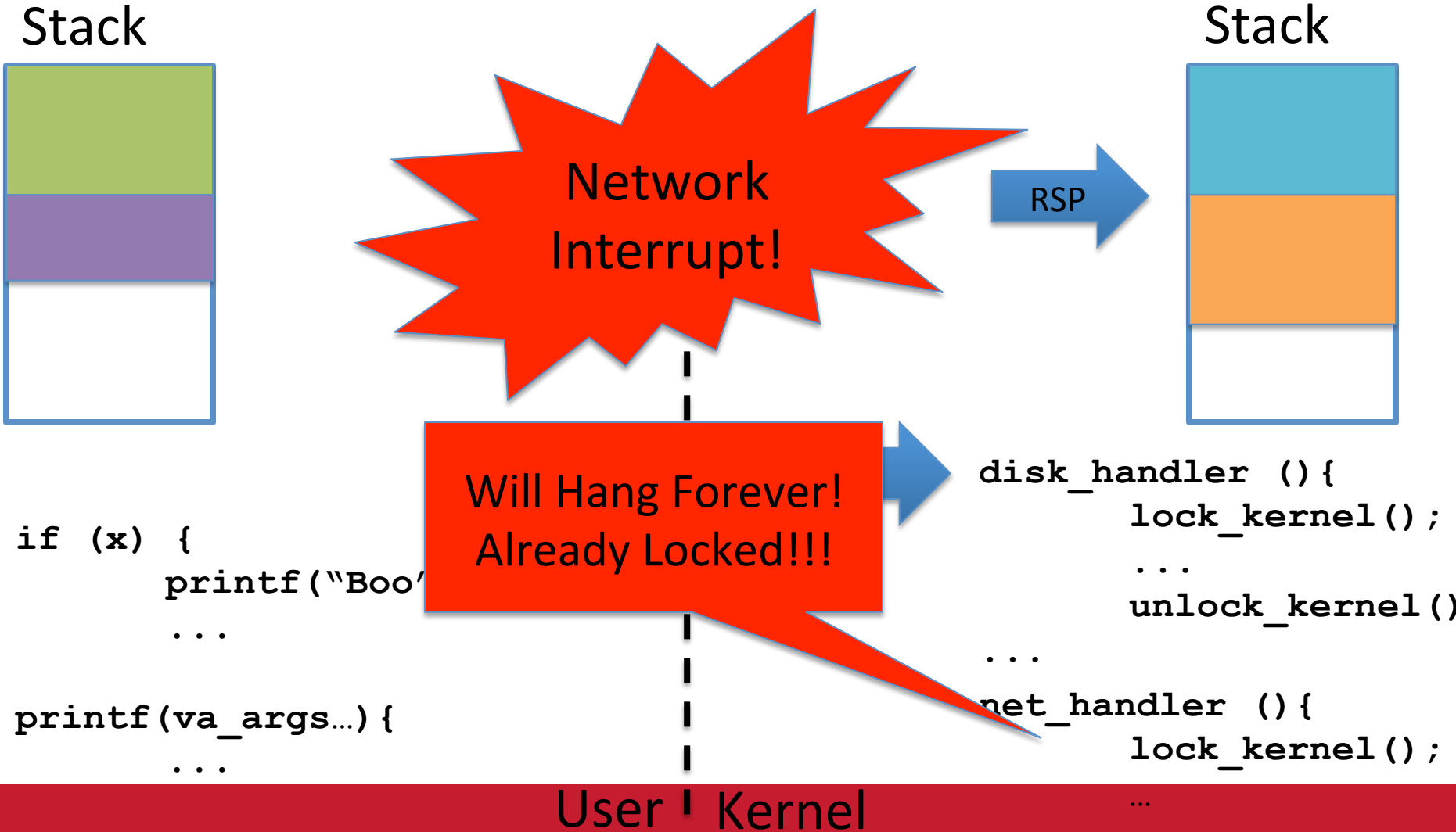

## Bottom Line:

- Interrupt service routines must be reentrant or synchronize
- Period.

## Hardware interrupt sync.

- While a CPU is servicing an interrupt on a given IRQ line, the same IRQ won't raise another interrupt until the routine completes
  - Bottom-line: device interrupt handler doesn't have to worry about being interrupted by itself
- *A different* device can interrupt the handler
  - Problematic if they share data structures
  - Like a list of free physical pages...
  - What if both try to grab a lock for the free list?

# Disabling interrupts

- An x86 CPU can disable I/O interrupts
  - Clear bit 9 of the EFLAGS register (IF Flag)
  - `ccli` and `stti` instructions clear and set this flag
- Before touching a shared data structure (or grabbing a lock), an interrupt handler should disable I/O interrupts

## Gate types

- Recall: an IDT entry can be an interrupt or an exception gate
- Difference?
  - An interrupt gate automatically disables all other interrupts (i.e., clears and sets IF on enter/exit)
  - An exception gate doesn't
- This is just a programmer convenience: you could do the same thing in software

# Exceptions

- You can't mask exceptions
  - Why not?
    - Can't make progress after a divide-by-zero
  - Double and Triple faults detect faults in the kernel
- Do exception handlers need to be reentrant?
  - Not if your kernel has no bugs (or system calls in itself)
  - In certain cases, Linux allows nested page faults
    - E.g., to detect errors copying user-provided buffers

# Summary

- Interrupt handlers need to synchronize, both with locks (multi-processor) and by disabling interrupts (same CPU)
- Exception handlers can't be masked
  - Nested exceptions generally avoided

# Lecture outline

- Overview
- How interrupts work in hardware
- How interrupt handlers work in software
- **How system calls work**
- New system call hardware on x86



# System call “interrupt”

- Originally, system calls issued using `int` instruction
- Dispatch routine was just an interrupt handler
- Like interrupts, system calls are arranged in a table
  - See `arch/x86/kernel/syscall_table*.S` in Linux source
- Program selects the one it wants by placing index in `eax` register
  - Arguments go in the other registers by calling convention
  - Return value goes in `eax`

# Lecture outline

- Overview
- How interrupts work in hardware
- How interrupt handlers work in software
- How system calls work
- **New system call hardware on x86**

## Around P4 era...

- Processors got very deeply pipelined
  - Pipeline stalls/flushes became very expensive
  - Cache misses can cause pipeline stalls
- System calls took twice as long from P3 to P4
  - Why?
  - IDT entry may not be in the cache
  - Different permissions constrain instruction reordering

## Idea

- What if we cache the IDT entry for a system call in a special CPU register?
  - No more cache misses for the IDT!
  - Maybe we can also do more optimizations
- Assumption: system calls are frequent enough to be worth the transistor budget to implement this
  - What else could you do with extra transistors that helps performance?

## AMD: `syscall/sysret`

- These instructions use MSR (machine specific registers) to store:
  - `syscall` entry point and code segment
  - Kernel stack
- A drop-in replacement for `int 0x80`
- Everyone loved it and adopted it wholesale
  - Even Intel!

# Aftermath

- Getpid() on my desktop machine (recent AMD 6-core):
  - Int 80: 371 cycles
  - Syscall: 231 cycles
- So system calls are definitely faster as a result!

## In JOS

- You will use the `int` instruction to implement system calls
- There is a challenge problem in lab 3 (i.e., extra credit) to use `systementer/sysexit`
  - Note that there are some more details about register saving to deal with
  - `syscall/sysret` is a bit too trivial for extra credit
    - But still cool if you get it working!

# Summary

- Interrupt handlers are specified in the IDT
- Understand when nested interrupts can happen
  - And how to prevent them when unsafe
- Understand optimized system call instructions
  - Be able to explain vdso, syscall vs. int 80