

THE UNIVERSITY of NORTH CAROLINA at CHAPEL HILL COMP 790: OS Implementation

# Device I/O Programming

Don Porter

1

1

THE UNIVERSITY of NORTH CAROLINA at CHAPEL HILL COMP 790: OS Implementation

## Logical Diagram

2

2

THE UNIVERSITY of NORTH CAROLINA at CHAPEL HILL COMP 790: OS Implementation

## Overview

- Many artifacts of hardware evolution
  - Configurability isn't free
  - Bake-in some reasonable assumptions
  - Initially reasonable assumptions get stale
  - Find ways to work-around going forward
    - Keep backwards compatibility
- General issues and abstractions

3

3

THE UNIVERSITY of NORTH CAROLINA at CHAPEL HILL COMP 790: OS Implementation

## PC Hardware Overview

- From wikipedia
- Replace AGP with PCIe
- Northbridge being absorbed into CPU on newer systems
- This topology is (mostly) abstracted from programmer

4

4

THE UNIVERSITY of NORTH CAROLINA at CHAPEL HILL COMP 790: OS Implementation

## I/O Ports

- Initial x86 model: separate memory and I/O space
  - Memory uses virtual addresses
  - Devices accessed via ports
- A port is just an address (like memory)
  - Port 0x1000 is not the same as address 0x1000
  - Different instructions – inb, inw, outl, etc.

5

5

THE UNIVERSITY of NORTH CAROLINA at CHAPEL HILL COMP 790: OS Implementation

## More on ports

- A port maps onto input pins/registers on a device
- Unlike memory, writing to a port has side-effects
  - “Launch” opcode to /dev/missiles
  - So can reading!
  - Memory can safely duplicate operations/cache results
- Idiosyncrasy: composition doesn't necessarily work
  - outw 0x1010 <port> != outb 0x10 <port>  
outb 0x10 <port+1>

6

6

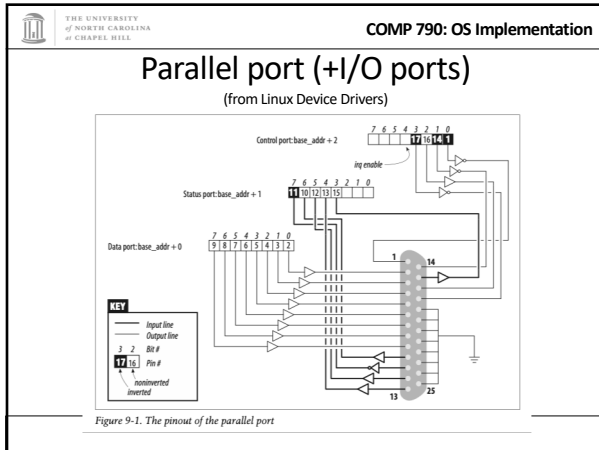

7

THE UNIVERSITY of NORTH CAROLINA at CHAPEL HILL

COMP 790: OS Implementation

### Port permissions

- Can be set with IOPL flag in EFLAGS
- Or at finer granularity with a bitmap in task state segment
  - Recall: this is the “other” reason people care about the TSS

8

THE UNIVERSITY of NORTH CAROLINA at CHAPEL HILL

COMP 790: OS Implementation

### Buses

- Buses are the computer’s “plumbing” between major components
- There is a bus between RAM and CPUs
- There is often another bus between certain types of devices
  - For inter-operability, these buses tend to have standard specifications (e.g., PCI, ISA, AGP)
  - Any device that meets bus specification should work on a motherboard that supports the bus

9

THE UNIVERSITY of NORTH CAROLINA at CHAPEL HILL

COMP 790: OS Implementation

### Clocks (again, but different)

- CPU Clock Speed: What does it mean at electrical level?
  - New inputs raise current on some wires, lower on others
  - How long to propagate through all logic gates?
  - Clock speed sets a safe upper bound
    - Things like distance, wire size can affect propagation time
  - At end of a clock cycle read outputs reliably
    - May be in a transient state mid-cycle
- Not talking about timer device, which raises interrupts at wall clock time; talking about CPU GHz

10

THE UNIVERSITY of NORTH CAROLINA at CHAPEL HILL

COMP 790: OS Implementation

### Clock imbalance

- All processors have a clock
  - Including the chips on every device in your system
  - Network card, disk controller, usb controller, etc.
  - And bus controllers have a clock
- Think now about older devices on a newer CPU
  - Newer CPU has a much faster clock cycle
  - It takes the older device longer to reliably read input from a bus than it does for the CPU to write it

11

THE UNIVERSITY of NORTH CAROLINA at CHAPEL HILL

COMP 790: OS Implementation

### More clock imbalance

- Ex: a CPU might be able to write 4 different values into a device input register before the device has finished one clock cycle
- Driver writer needs to know this
  - Read from manuals
- Driver must calibrate device access frequency to device speed
  - Figure out both speeds, do math, add delays between ops
  - You will do this in lab 6! (outb 0x80 is handy!)

12

THE UNIVERSITY OF NORTH CAROLINA @ CHAPEL HILL COMP 790: OS Implementation

### CISC silliness?

- Is there any good reason to use dedicated instructions and address space for devices?
- Why not treat device input and output registers as regions of physical memory?

13

THE UNIVERSITY OF NORTH CAROLINA @ CHAPEL HILL COMP 790: OS Implementation

### Simplification

- Map devices onto regions of physical memory
  - Hardware basically redirects these accesses away from RAM at same location (if any), to devices
  - A bummer if you “lose” some RAM
- Win: Cast interface regions to a structure
  - Write updates to different areas using high-level languages
  - Still subject to timing, side-effect caveats

14

THE UNIVERSITY OF NORTH CAROLINA @ CHAPEL HILL COMP 790: OS Implementation

### Optimizations

- How does the compiler (and CPU) know which regions have side-effects and other constraints?
  - It doesn't: programmer must specify!

15

THE UNIVERSITY OF NORTH CAROLINA @ CHAPEL HILL COMP 790: OS Implementation

### Optimizations (2)

- Recall: Common optimizations (compiler and CPU)
  - Out-of-order execution
  - Reorder writes
  - Cache values in registers
- When we write to a device, we want the write to really happen, now!
  - Do not keep it in a register, do not collect \$200
- Note: both CPU and compiler optimizations must be disabled

16

THE UNIVERSITY OF NORTH CAROLINA @ CHAPEL HILL COMP 790: OS Implementation

### volatile keyword

- A volatile variable cannot be cached in a register
  - Writes must go directly to memory
  - Reads must always come from memory/cache
- volatile code blocks cannot be reordered by the compiler
  - Must be executed precisely at this point in program
  - E.g., inline assembly
- `__volatile__` means I really mean it!

17

THE UNIVERSITY OF NORTH CAROLINA @ CHAPEL HILL COMP 790: OS Implementation

### Compiler barriers

- Inline assembly has a set of clobber registers
  - Hand-written assembly will clobber them
  - Compiler's job is to save values back to memory before inline asm; no caching anything in these registers
- “memory” says to flush all registers
  - Ensures that compiler generates code for all writes to memory before a given operation

18

THE UNIVERSITY of NORTH CAROLINA at CHAPEL HILL COMP 790: OS Implementation

### CPU Barriers

- Advanced topic: Don't need details
- Basic idea: In some cases, CPU can issue loads and stores out of program order (optimize perf)
  - Subject to many constraints on x86 in practice
- In some cases, a “fence” instruction is required to ensure that pending loads/stores happen before the CPU moves forward
  - Rarely needed except in device drivers and lock-free data structures

19

THE UNIVERSITY of NORTH CAROLINA at CHAPEL HILL COMP 790: OS Implementation

### Configuration

- Where does all of this come from?
  - Who sets up port mapping and I/O memory mappings?
  - Who maps device interrupts onto IRQ lines?
- Generally, the BIOS
  - Sometimes constrained by device limitations
  - Older devices hard-coded IRQs
  - Older devices may only have a 16-bit chip
    - Can only access lower memory addresses

20

THE UNIVERSITY of NORTH CAROLINA at CHAPEL HILL COMP 790: OS Implementation

### ISA memory hole

- Recall the “memory hole” from lab 2?
  - 640 KB – 1 MB
- Required by the old ISA bus standard for I/O mappings
  - No one in the 80s could fathom > 640 KB of RAM
  - Devices sometimes hard-coded assumptions that they would be in this range
  - Generally reserved on x86 systems (like JOS)
  - Strong incentive to save these addresses when possible

21

THE UNIVERSITY of NORTH CAROLINA at CHAPEL HILL COMP 790: OS Implementation

### New hotness: PCI

- Hard-coding things is bad
  - Willing to pay for flexibility in mapping devices to IRQs and memory regions
- Guessing what device you have is bad
  - On some devices, you had to do something to create an interrupt, and see what fired on the CPU to figure out what IRQ you had
  - Need a standard interface to query configurations

22

THE UNIVERSITY of NORTH CAROLINA at CHAPEL HILL COMP 790: OS Implementation

### More flexibility

- PCI addressing (both memory and I/O ports) are dynamically configured
  - Generally by the BIOS
  - But could be remapped by the kernel
- Configuration space
  - 256 bytes per device (4k per device in PCIe)
  - Standard layout per device, including unique ID
  - Big win: standard way to figure out my hardware, what to load, etc.

23

THE UNIVERSITY of NORTH CAROLINA at CHAPEL HILL COMP 790: OS Implementation

### PCI Configuration Layout

From device driver book

|      |                            |           |              |                |             |            |                     |                     |                     |                |     |     |     |     |     |  |
|------|----------------------------|-----------|--------------|----------------|-------------|------------|---------------------|---------------------|---------------------|----------------|-----|-----|-----|-----|-----|--|
| 0x0  | 0x1                        | 0x2       | 0x3          | 0x4            | 0x5         | 0x6        | 0x7                 | 0x8                 | 0x9                 | 0xa            | 0xb | 0xc | 0xd | 0xe | 0xf |  |
| 0x00 | Vendor ID                  | Device ID | Command Reg. | Status Reg.    | Revision ID | Class Code | Cache Line          | Latency Timer       | Header Type         | BIST           |     |     |     |     |     |  |
| 0x10 | Base Address 0             |           |              | Base Address 1 |             |            | Base Address 2      |                     |                     | Base Address 3 |     |     |     |     |     |  |
| 0x20 | Base Address 4             |           |              | Base Address 5 |             |            | CardBus CIS pointer | Subsystem Vendor ID | Subsystem Device ID |                |     |     |     |     |     |  |
| 0x30 | Expansion ROM Base Address |           |              | Reserved       |             |            | IRQ Line            | IRQ Pin             | Min_Gnt             | Max_Lat        |     |     |     |     |     |  |

- Required Register  
 - Optional Register

Figure 12-2. The standardized PCI configuration registers

24

THE UNIVERSITY OF NORTH CAROLINA at CHAPEL HILL

COMP 790: OS Implementation

## PCI Overview

- Most desktop systems have 2+ PCI buses
  - Joined by a bridge device
  - Forms a tree structure (bridges have children)

25

THE UNIVERSITY OF NORTH CAROLINA at CHAPEL HILL

COMP 790: OS Implementation

## PCI Layout

From Linux Device Drivers

Figure 12-1. Layout of a typical PCI system

26

THE UNIVERSITY OF NORTH CAROLINA at CHAPEL HILL

COMP 790: OS Implementation

## PCI Addressing

- Each peripheral listed by:
  - Bus Number (up to 256 per domain or host)
    - A large system can have multiple domains
  - Device Number (32 per bus)
  - Function Number (8 per device)
    - Function, as in type of device, not a subroutine
    - E.g., Video capture card may have one audio function and one video function
- Devices addressed by a 16 bit number

27

THE UNIVERSITY OF NORTH CAROLINA at CHAPEL HILL

COMP 790: OS Implementation

## PCI Interrupts

- Each PCI slot has 4 interrupt pins
- Device does not worry about how those are mapped to IRQ lines on the CPU
  - An APIC or other intermediate chip does this mapping
- Bonus: flexibility!
  - Sharing limited IRQ lines is a hassle. Why?
    - Trap handler must demultiplex interrupts
  - Being able to “load balance” the IRQs is useful

28

THE UNIVERSITY OF NORTH CAROLINA at CHAPEL HILL

COMP 790: OS Implementation

## Direct Memory Access (DMA)

- Simple memory read/write model bounces all I/O through the CPU
  - Fine for small data, totally awful for huge data
- Idea: just write where you want data to go (or come from) to device
  - Let device do bulk data transfers into memory without CPU intervention
  - Interrupt CPU on I/O completion (asynchronous)

29

THE UNIVERSITY OF NORTH CAROLINA at CHAPEL HILL

COMP 790: OS Implementation

## DMA Buffers

- DMA buffers must be physically contiguous
- Devices do not go through page tables
- Some buses (SBus) can use virtual addresses; most (PCI) use physical (avoid page translation overheads)

30

THE UNIVERSITY OF NORTH CAROLINA @ CHAPEL HILL COMP 790: OS Implementation

## Ring buffers

- Many devices pre-allocate a “ring” of buffers
  - Think network card
- Device writes into ring; CPU reads behind
- If ring is well-sized to the load:
  - No dynamic buffer allocation
  - No stalls
- Trade-off between device stalls (or dropped packets) and memory overheads

31

THE UNIVERSITY OF NORTH CAROLINA @ CHAPEL HILL COMP 790: OS Implementation

## IOMMU

- It is a pain to allocate physically contiguous regions
- Idea: “virtual addresses” for devices
  - We can take random physical pages and make them look contiguous to the device
  - Called “Bus address” for clarity
- New to the x86 (called VT-d)
  - Until very recently, x86 kernels just suffered

32

THE UNIVERSITY OF NORTH CAROLINA @ CHAPEL HILL COMP 790: OS Implementation

## A note on memory protection

- If I can write to a network card’s control register and tell it where to write the next packet
  - What if I give it an address used for something else?
    - Like another process’s address space
  - Nothing stops this
- DMA privilege effectively equals privilege to write to any address in physical memory!

33

THE UNIVERSITY OF NORTH CAROLINA @ CHAPEL HILL COMP 790: OS Implementation

## Why does x86 now care about IOMMUs?

- Virtualization! (VT-d)
- Scenario: system with 4 NICs, 4 VMs
- Without IOMMU: Hypervisor must mediate all network traffic
- With IOMMU: Each VM can have a different virtual bus address space
  - Looks like a single NIC; can only issue DMAs for its own memory (not other VM’s memory)
  - No Hypervisor mediation needed!

34

THE UNIVERSITY OF NORTH CAROLINA @ CHAPEL HILL COMP 790: OS Implementation

## VT-d Limitations

- IOMMU device restrictions are all-or-nothing
  - Can’t share a network card
  - Although some devices may fix this too
- VT-d is only for devices on the PCI-Express bus
  - Usually just graphics and high-end network cards
  - Legacy PCI devices are behind a bridge
    - All-or-nothing for an entire bridge
  - Similarly, no per-disk access control
    - All-or-nothing for disk controller (which multiplexes disks)

35

THE UNIVERSITY OF NORTH CAROLINA @ CHAPEL HILL COMP 790: OS Implementation

## Summary

- How to access devices: ports or memory
- Issues with CPU optimizations, timing delays, etc.
- Overview of PCI bus
- Overview of DMA and protection issues
  - IOMMU and use for virtualization

36